



**GLOBO**

**Stockholm**

# Stockholm

design Claesson Koivisto Rune

## Indice *Index*

**p. 03**

New landscape in bathroom - Introduzione  
*New landscape in bathroom - Introduction*

**p. 06**

Collezione Stockholm  
*Stockholm collection*

**p. 13**

Globo e il colore  
*Globo and colour*

**p. 20**

CERASLIDE® - Nuovo smalto ceramico  
*Ceraslide® - New ceramic glaze*

**p. 23**

Fissaggioghost®  
*Fissaggioghost®*

**p. 29**

Vasomulti®  
*Bidetmulti®*

**p. 31**

Vaso-bidet  
*Wc-bidet*

**p. 33**

Sgancio rapido  
*Easy detach*

**p. 34**

Elementi  
*Elements*

**p. 36**

Parte tecnica  
*Technical section*

**p. 46**

Colori ceramici disponibili  
*Available ceramic colours*

**p. 47**

Claesson Koivisto Rune

**GLOBO**



## Stockholm

### *New landscape in bathroom*

Benessere per il corpo, gioia per l'anima - *Wellness for the body, joy for the soul*

Fruire di eleganza e qualità sin dal risveglio e riscoprire ogni giorno la purezza dell'essenzialità. Ecco la prerogativa della collezione Stockholm, che grazie alla dolcezza delle curve e alla raffinatezza delle linee nette, dona estrema armonia e semplicità al luogo più intimo della casa. Nasce così un paesaggio in cui il benessere si sposa con il comfort in un tripudio di bellezza che dura nel tempo.

*To enjoy elegance and quality from the time you wake up and to rediscover the purity of essentiality day after day. This is the prerogative of the Stockholm series, whose soft curves and sophisticated lines gives extreme harmony and simplicity to the most intimate room in the home. The result is a landscape where wellbeing combines with comfort in a blaze of timeless beauty*

I gesti del benessere donano una carica di energia e un dolce relax, il giusto mix che permette a corpo e mente di rigenerarsi in ogni momento della giornata.

*The gestures of wellbeing give a boost of energy and gentle relaxation, the right mix to allow the body and mind to regenerate at any time of the day.*



# Stockholm

design Claesson Koivisto Rune

Si ispira alla ricchezza formale della natura, caratterizzata tanto da profili curvi e dolci quanto da linee nette e definite, la nuova collezione Stockholm firmata dal trio svedese Claesson Koivisto Rune. La sfida progettuale è quella di modificare le forme tradizionali di lavandini, vasi e bidet, definite negli anni per raggiungere la massima funzionalità, con alterazioni molto delicate per ottenere armonia volumetrica e bellezza. La collezione di sanitari Stockholm è scolpita con linee rette interconnesse, forme a scatola e forme a ciotola, che si fondono le une nelle altre conciliando elementi opposti come la linea e la curva, il quadrato e il rotondo.

*The new Stockholm collection, designed by the swedish trio Claesson Koivisto Rune, is inspired by the formal richness of nature, characterised by curved and gentle profiles and well-defined lines. The challenge was to change the traditional forms of washbasins, toilet bowls and bidets, which were defined over the years to achieve maximum functionality, and to introduce very subtle alterations to add volumetric harmony and beauty. The collection of Stockholm sanitaryware is sculpted with interconnecting straight lines, box shapes, which merge into other to reconcile contrasting elements such as lines and curves, squares and round shapes.*



▶  
**LA045.BI**  
Lavabo da appoggio  
Countertop basin  
45.37



◀  
**FO105.BI**  
Lavabo da incasso  
Recessed basin  
105.34

**LAS02.BI**  
Wc sospeso  
Wall-hung wc  
58.37

**LAS09.BI**  
Bidet sospeso  
Wall-hung bidet  
58.37  
▼



LA102.BI  
Lavabo sospeso  
Wall-hung basin  
102.45



Il piano non è in produzione / The shell is not in production



▲  
**FO076.BI**  
Lavabo sottopiano  
*Under-top basin*  
75.34

**LA080.BI**  
Lavabo sospeso  
*Wall-hung basin*  
80.50

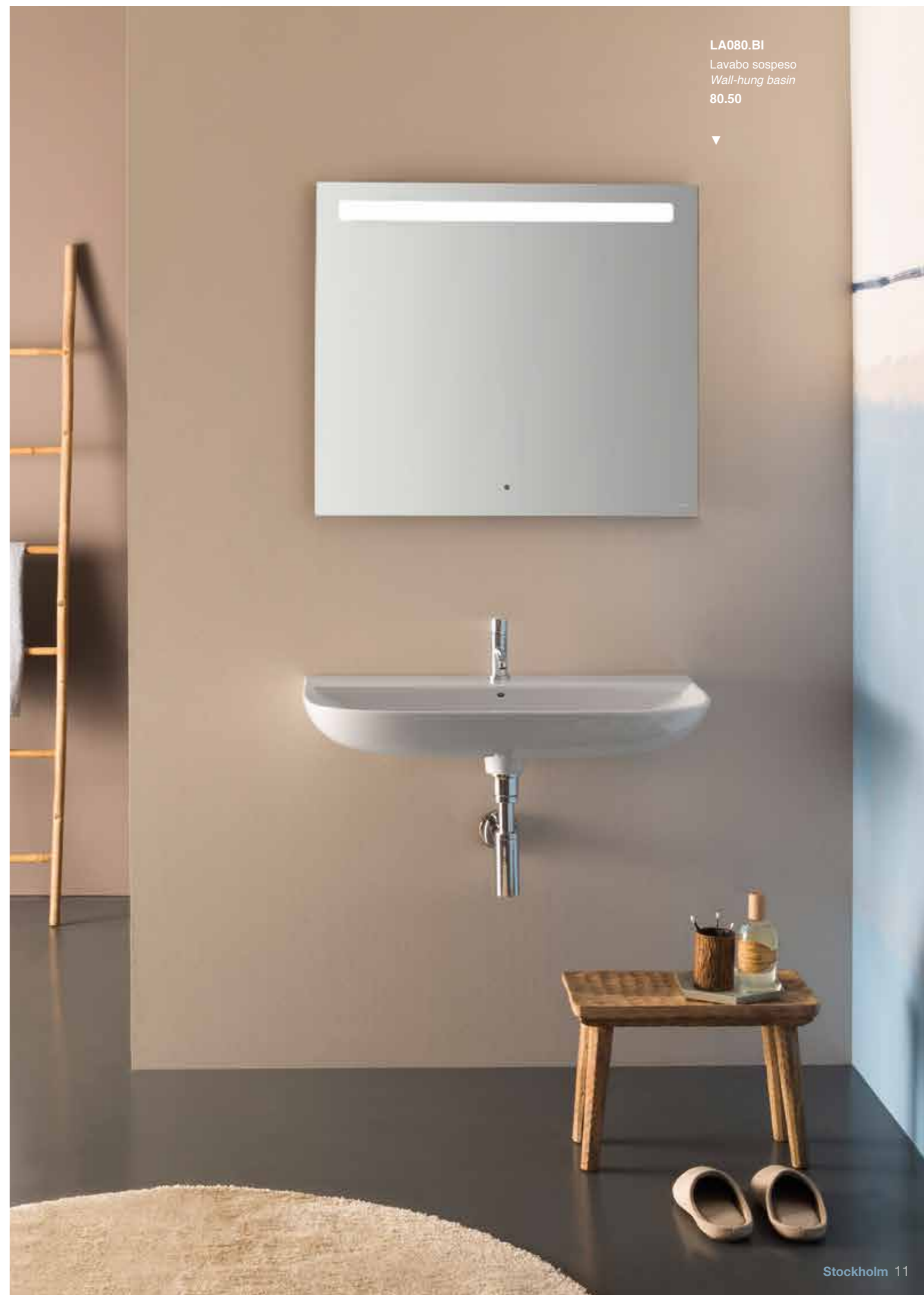



▼  
**LA080.MA**  
 Lavabo sospeso  
 Wall-hung basin  
 80.50

▼  
**LAS02.MA**  
 Vaso sospeso  
 Wall-hung wc  
 58.37

## Malva

Il colore regale dell'Età Moderna, sobria tonalità violacea.

*The royal colour of the Modern Age, subtle purplish hues.*



## Globo e il colore

*Globo and colour*

La ricerca sul colore intrapresa da Globo in questi ultimi anni, ha portato alla concezione di nuove finiture da applicare sui propri prodotti. Il colore è protagonista della nostra vita e del mondo domestico. Come tale, Globo sperimenta nuove proposte da inserire nell'ambiente bagno diventando figura di riferimento e fonte di ispirazioni per architetti e designers.

*The colour research undertaken by Globo in recent years has led to the conception of new finishes for its products. Colour is a vital part of our life and home. For this reason, Globo experiments with new bathroom proposals, becoming a reference and source of inspiration for architects and designers.*





◀  
**FO056.BI**  
 Lavabo da incasso  
*Recessed basin*  
 55.34

Il piano non è in produzione / The shelf is not in production



▲  
**LA071.BI**  
 Lavabo da appoggio  
*Countertop basin*  
 70.37



◀  
**FO091.BI**  
 Lavabo sottopiano  
*Under-top basin*  
 90.34

▼  
**LA001.BI**  
 VASOMULTI®  
 VASOGHOST®  
 Vaso a terra  
*Floor mounted wc*  
**58.37**

**LA009.BI**  
 BIDETMULTI®  
 BIDETGHOST®  
 Bidet a terra  
*Floor mounted bidet*  
**58.37**



▼  
**LA055.BI**  
 Lavabo sospeso  
*Wall-hung basin*  
 55.37



▶  
**LAS09.BI**  
 Bidet sospeso  
*Wall-hung bidet*  
 58.37

▶  
**LAS02.BI**  
 Vaso sospeso  
*Wall-hung wc*  
 58.37

▶  
**LA084.BI**  
 Lavabo sospeso  
*Wall-hung basin*  
 84.45



Ceraslide®

GLOBO



CERASLIDE®

Nuovo smalto ceramico  
New ceramic glaze

**i**

Disponibile per la prima volta  
con la collezione STOCKHOLM.  
A breve per tutte le altre.

Available for the first time  
with the STOCKHOLM collection.  
Short for all the other.

Vantaggi / Benefits



Resistenza alle  
macchie, all'abrasione  
*Resistance to stains,  
abrasions*



Igiene più profonda  
e più a lungo  
*Hygiene deeper  
and longer*



Colore più omogeneo  
e brillante  
*More homogeneous  
and brighter colour.*

Frutto della ricerca di Ceramica Globo, nasce l'innovativo smalto CERASLIDE®. Questa nuova formulazione, studiata e testata a fondo per ottenere un'efficacia inalterabile nel tempo, viene applicata sui prodotti garantendo alla ceramica una protezione uniforme.

L'attento controllo delle temperature nelle varie fasi di cottura, in un ciclo che arriva a 26 ore, garantiscono al processo di sinterizzazione una perfetta omogeneità del prodotto, diminuendo la porosità e assicurando una maggiore resistenza alle macchie, allo sporco e all'abrasione; in questo modo i residui non aderiscono alle pareti scivolando insieme all'acqua per un'igiene più profonda e più a lungo; questo effetto barriera inoltre riduce notevolmente la crescita batterica.

Le caratteristiche di CERASLIDE® aumentano, al tempo stesso, la resistenza chimica della ceramica nei confronti di agenti acidi e alcalini, contenuti nella maggior parte dei detersivi comunemente utilizzati per la pulizia del bagno. Tutto questo si traduce in una qualità più duratura dei prodotti, una superficie levigata al tatto e alla vista e un colore più omogeneo e brillante.

La composizione dello smalto CERASLIDE® seleziona e utilizza esclusivamente materie prime di qualità superiore, assolutamente innocue per la salute e nel rispetto dell'ambiente, confermando ancora una volta la vocazione green dell'azienda.

*From Ceramica Globo's research comes the innovative CERASLIDE® glaze for ceramics. This new formulation has been carefully designed and tested to maintain its characteristics over time and is applied on ceramic products to ensure uniform protection.*

*The accurate temperature control during the various cooking stages, in a cycle that lasts 26 hours, ensures perfect homogeneity of the product during the sintering process, reducing porosity and guaranteeing greater resistance to stains, dirt and abrasions. Residues do not adhere to the walls and slide off with water to provide deeper and long-lasting hygiene. This barrier effect also significantly reduces bacterial growth.*

*At the same time, the characteristics of CERASLIDE® increase the chemical resistance of ceramics against acid and alkaline agents contained in detergents commonly used to clean the bathroom. All this means longer lasting products, smoother surfaces, and a more homogeneous and brighter colour.*

*The CERASLIDE® glaze is made from the finest raw materials that do not harm people and the environment, confirming once again the "green heart" of the company.*



LA001.BI

Vaso a terra  
Floor mounted wc  
58.37

LA009.BI

Bidet a terra  
Floor mounted bidet  
58.37

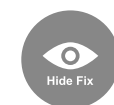

## FISSAGGIOGHOST®

Il sistema di fissaggio dei vasi e bidet a terra  
*Hidden fixing system of floor-mounted WC and bidet*

Il sistema di fissaggio dei vasi e bidet a terra è completamente nascosto, grazie a un brevetto sviluppato ed ingegnerizzato da Ceramica Globo. Il sanitario è così saldamente fissato al pavimento lasciando il design del pezzo perfettamente intatto senza interruzioni.

*The fixing system of floor-mounted WC and bidet is completely hidden, thanks to a patented system created and developed by Ceramica Globo. Therefore, the sanitaries are firmly fixed, keeping intact and without interruptions the design of the product, improving considerably the aesthetics of the item.*





**LAS02.BI**  
Vaso sospeso  
Wall-hung wc  
58.37



**LAS09.BI**  
Bidet sospeso  
Wall-hung bidet  
58.37



**FO056.BI**  
Lavabo da incasso  
Recessed basin  
55.34



Il piano non è in produzione / The shelf is not in production



▲  
**LA001.BI**  
Wc a terra  
*Floor mounted Wc*  
58.37



▲  
**LA009.BI**  
Bidet a terra  
*Floor mounted bidet*  
58.37





## VASOMULTI® BIDETMULTI®

Vaso e bibet a terra  
*Floor mounted wc e bidet*

Vantaggi / Benefits



Ideale per ristrutturazioni  
*Ideal for renovation*

MULTI è l'innovativo sistema ideato da Ceramica Globo che consente di allacciarsi su scarichi e attacchi idraulici esistenti, per l'installazione di vasi e bidet a terra filo parete. Il VASOMULTI® può essere installato sul vecchio scarico, generalmente posto ad una distanza da 6 a 21 cm. dalla parete, mediante l'utilizzo di 3 diverse curve tecniche. I BIDETMULTI® sono, invece, realizzati in modo da ospitare al suo interno i vecchi allacci idraulici, nascondendoli alla vista. Il sistema MULTI offre l'opportunità di ristrutturare il bagno senza sostenere le spese per il rifacimento degli scarichi, degli allacci idraulici e talvolta anche dei rivestimenti. È ideale per offrire soluzioni di design nei "fuoricapitolato" e nelle ristrutturazioni di vecchi bagni. Il sistema MULTI è attualmente disponibile sui Vasi e bidet a terra STONE, BOWL+, 4ALL, FORTY3 e STOCKHOLM consentendo una possibilità di scelta nelle forme estetiche che meglio si armonizzano con l'ambiente bagno.

*MULTI is an innovative system conceived by Ceramica Globo that can be connected to existing drains and water connections for back-to-wall installation of toilets and bidets. VASOMULTI® can be mounted on the old drain, generally placed at a distance of 6 to 21 cm from the wall, through the use of 3 different curved techniques. Instead, the BIDETMULTI® system is designed to contain only hydraulic connections, hiding them from view. The MULTI system allows renovating the bathroom without extra costs to adapt drains, hydraulic connections and sometimes even wall and floor coverings. It is ideal for non-standard solutions and for the renovation of old bathrooms.*

*The MULTI system is currently available on floor-mounted toilets and bidets from the STONE, BOWL+, and 4ALL FORTY3 e STOCKHOLM series, allowing to choose the aesthetic forms that best harmonise with the bathroom environment.*

Prima della ristrutturazione. Vaso da sostituire  
*Before the renovation. Vaso to be replaced*

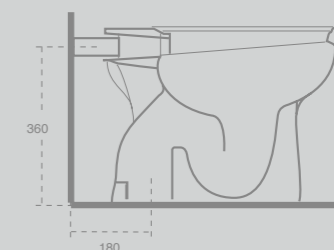

VASOMULTI® Grazie al raccordo eccentrico e curva tecnica si adegua alle quote preesistenti  
*VASOMULTI® The eccentric curved connection allows adapting to existing heights*

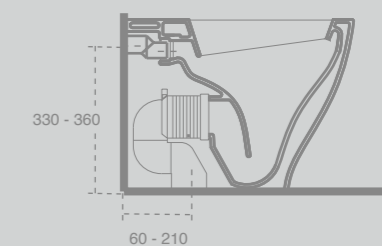

Prima della ristrutturazione. Bidet da sostituire  
*Before the renovation. Bidet to be replaced*

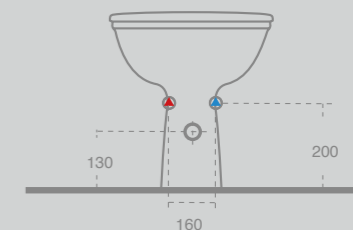

BIDETMULTI® Grazie alla sua apertura posteriore si adegua alle quote preesistenti  
*BIDETMULTI® Its rear opening allows it to adapt to existing heights*

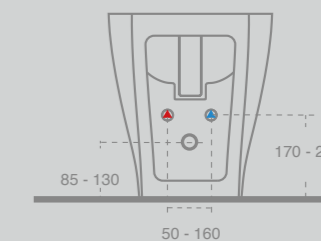

Quote d'installazione per STOCKHOLM  
*Installation dimensions for STOCKHOLM*





**FO076.BI**  
Lavabo sottopiano  
*Under-top basin*  
75.34



**LAB02.BI**  
Vaso-bidet sospeso  
*Wall-hung wc-bidet*  
58.37



## Vaso-Bidet

Vaso-bidet  
*Wc-bidet*

Vantaggi / *Benefits*



Ideale per  
spazi ristretti  
*Ideal for restricted  
spaces*



Garantisce un risparmio  
economico e di risorse  
ambientali  
*Guarantees a saving of  
costs and environmental  
resources*

Due funzioni, wc e bidet, in un unico prodotto. I vasi-bidet Globo nascono per unire esigenze differenti, utili in spazi ristretti per la loro duplice funzione, in secondi bagni e ristrutturazioni. L'erogatore posto nella parte posteriore permette l'uso del sanitario come bidet consentendo notevole risparmio idrico ed economico.

*Two functions, pan and bidet, in one product. Globo pan-bidet are created to match different needs, they are perfect for small spaces thanks to their double function, for secondary bathrooms and for renovations. The supplying located in the backside of the pan allows to use the product as a bidet and enables thus to decrease considerably economical and water waste.*





## Easy detach

Il sistema di cerniere a sgancio rapido  
*The system of quick release hinges*

Vantaggi / Benefits



Facilità di pulizia  
*Easy to clean*

Le nuove cerniere a sgancio rapido, permettono di rimuovere il coprivaso con un gesto semplice e veloce grazie al particolare modello, dotato a lato, di pulsante. Infatti premendo entrambi i pulsanti e tirando il sedile verso l'alto questo si sgancia dai piantoni. Rimettendo le due cerniere sui piantoni e spingendo verso il basso queste si riportano in posizione bloccandosi. Grazie a questo sistema è garantita sia la possibilità di smontare e montare velocemente il coprivaso sia la facilità di pulizia dello stesso e delle zone adiacenti, spesso difficili da pulire. Questa cerniera è disponibile sia nella versione tradizionale che soft-close.

The new quick-release hinges allow removing the toilet seat with a simple and quick gesture thanks to special hinges fitted with side buttons. In fact, the seat can easily be disengaged from the guides by simply pressing both buttons and pulling it upwards. The two hinges can then be brought back to the locked position by replacing them on the guides and pushing downwards.

This system enables quick assembly and disassembly of the toilet seat for easy cleaning of the seat itself and the surrounding area, which is often difficult to clean. This hinge is available in both the traditional and soft-close versions.

### Materiali dei coprivasi

- I coprivasi di ceramica GLOBO sono realizzati in DUROPLAST ottenuto fondendo in stampi d'acciaio il materiale Urea formaldeide ricavato dal composto "UFA10".
- Le cerniere, sia tradizionali che a chiusura rallentata sono interamente prodotte in acciaio inossidabile ASI304 - INOX 18/8.
- I paracolpi sono realizzati in gomma termoplastica ad iniezione con elevata resistenza meccanica pur avendo maggior flessibilità rispetto a quelli in materiale plastico ,garantendo quindi maggior durata nel tempo.

### Materials of the seat covers

- The GLOBO ceramic seat covers are made in DUROPLAST obtained by melting in steel moulds the Urea formaldehyde material derived from the "UFA10" compound.
- Both the traditional and soft-close hinges are made entirely of ASI304 - INOX 18/8 stainless steel.
- The bumpers are made of rubber injection thermoplastic with high mechanical strength. They have greater flexibility than plastic bumpers and, therefore, last longer.

### PLUS

- RESISTENZA AL CARICO MASSIMO DI 240 kg
- RESISTENZA AL FUOCO
- DUROPLAST è un materiale completamente biodegradabile
- DUROPLAST è un materiale completamente anallergico
- DUROPLAST è un materiale completamente antistatico e quindi facile da pulire.

- RESISTANCE AT MAXIMUM LOAD OF 240 kg
- FIRE RESISTANCE
- DUROPLAST is a completely biodegradable material
- DUROPLAST is a completely hypoallergenic material
- DUROPLAST is a completely anti-static material and, therefore, easy to clean

**LA102.BI**  
Lavabo sospeso  
Wall-hung basin  
102.45



**LA071.BI**  
Lavabo appoggio  
Countertop basin  
70.37



**FO105.BI**  
Lavabo incasso  
Recessed basin  
105.34



**FO106.BI**  
Lavabo sottopiano  
Undertop basin  
105.34



**LAS02.BI**  
Vaso sospeso  
Wall-hung WC  
58.37



**LAS09.BI**  
Bidet sospeso  
Wall-hung bidet  
58.37



**LA084.BI**  
Lavabo sospeso  
Wall-hung basin  
84.45



**LA045.BI**  
Lavabo appoggio  
Countertop basin  
45.37



**FO090.BI**  
Lavabo incasso  
Recessed basin  
90.34



**FO091.BI**  
Lavabo sottopiano  
Undertop basin  
90.34



**LA001.BI**  
VASOGHOST®  
VASOMULTI®  
Floor mounted WC  
58.37



**LA009.BI**  
BIDETGHOST®  
BIDETMULTI®  
Floor mounted bidet  
58.37



**LA070.BI**  
Lavabo sospeso  
Wall-hung basin  
70.37



**FO075.BI**  
Lavabo incasso  
Recessed basin  
75.34



**FO076.BI**  
Lavabo sottopiano  
Undertop basin  
75.34



**LAB02.BI**  
Vaso-bidet sospeso  
Wall-hung Wc-Bidet  
58.37



**LAB01.BI**  
Vaso-bidet terra  
Floor mounted Wc-Bidet  
58.37



**LA055.BI**  
Lavabo sospeso  
Wall-hung basin  
55.37



**FO056.BI**  
Lavabo sospeso  
Recessed basin  
55.34



**FO057.BI**  
Lavabo sottopiano  
Undertop basin  
55.34



**LA080.BI**  
Lavabo sospeso  
Wall-hung basin  
80.50



\* Su tutti gli articoli in ceramica viene applicato il nuovo smalto CERASLIDE® senza costi aggiuntivi  
\* On all items in ceramic is applied the new glaze CERASLIDE® at no additional cost

## Stockholm

### Lavabo STOCKHOLM 102.45

Lavabo 102 predisposto monoforo. Con foro troppo pieno. Installazione sospesa. Completo di fissaggi. **LA102.BI**  
Basin 102cm arranged one tap hole. Provided with overflow hole. Wall-hung installation. Fixing kit included.

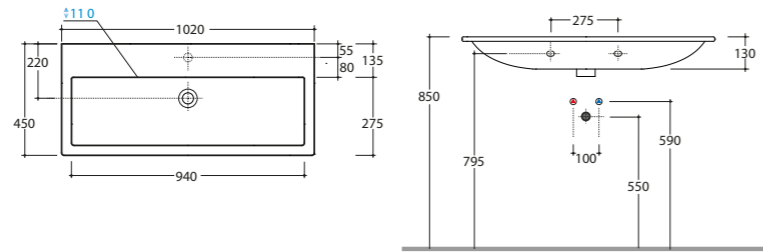

Disponibilità settembre 2015  
Availability September 2015



cm 102x45 h17 Pallet Italia pz.8 Pallet export pz.13 Europallet pz.10 kg.27

### Lavabo STOCKHOLM 84.45

Lavabo 84 predisposto monoforo. Con foro troppo pieno. Installazione sospesa. Completo di fissaggi. **LA084.BI**  
Basin 84cm arranged one tap hole. Provided with overflow hole. Wall-hung installation. Fixing kit included.

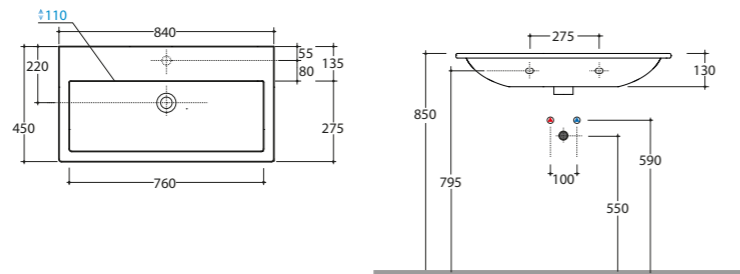

cm 84x45 h17 Pallet Italia pz.10 Pallet export pz.17 Europallet pz.12 kg.20

### Lavabo STOCKHOLM 70.37

Lavabo 70 predisposto monoforo. Con foro troppo pieno. Installazione sospesa. Completo di fissaggi. **LA070.BI**  
Basin 70cm arranged one tap hole. Provided with overflow hole. Wall-hung installation. Fixing kit included.

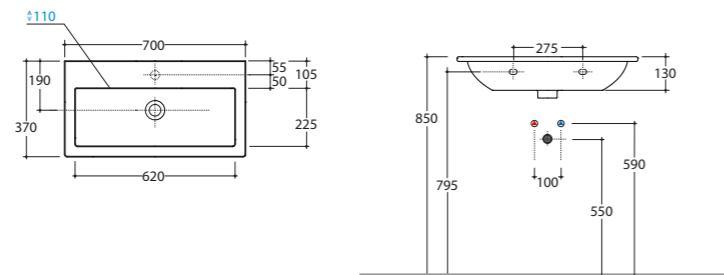

cm 70x37 h17 Pallet Italia pz.21 Pallet export pz.30 Europallet pz.26 kg.16

### Lavabo STOCKHOLM 55.37

Lavabo 55 predisposto monoforo. Con foro troppo pieno. Installazione sospesa. Completo di fissaggi. **LA055.BI**  
Basin 55cm arranged one tap hole. Provided with overflow hole. Wall-hung installation. Fixing kit included.

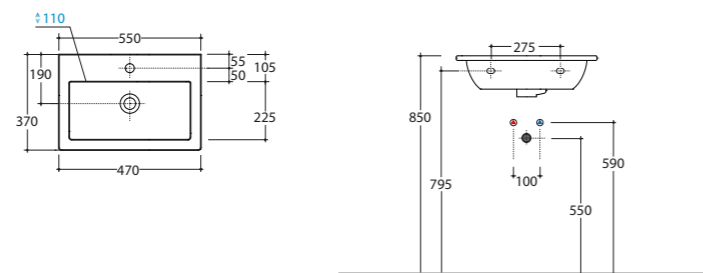

cm 55x37 h17 Pallet Italia pz.30 Pallet export pz.50 Europallet pz.36 kg.13

### Lavabo STOCKHOLM 80.50

Lavabo 80 predisposto monoforo. Con foro troppo pieno. Installazione sospesa. Completo di fissaggi. **LA080.BI**  
Basin arranged one tap hole 80cm, provided with overflow hole. Wall-hung installation. Fixing kit included.

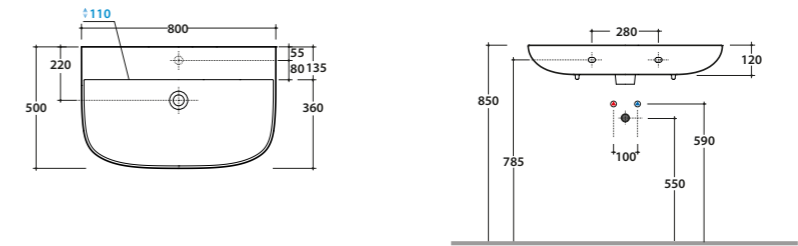

cm 80x50 h16,5 Pallet Italia pz.10 Pallet export pz.17 Europallet pz.14 kg.21

### Lavabo da appoggio STOCKHOLM 70.37

Lavabo 70. Senza foro troppopieno. Per rubinetteria a muro o su piano. Installazione da appoggio. **LA071.BI**  
Countertop basin 70cm, with no overflow hole. Suitable for wall mounted taps or on counter.

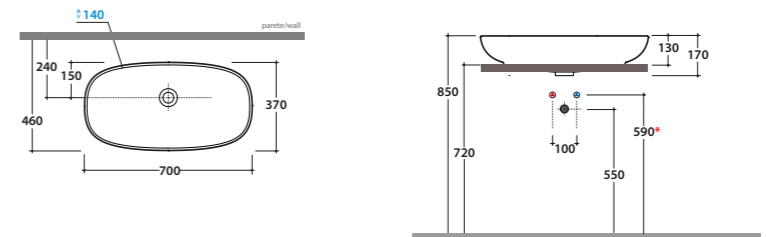

\* Per rubinetto su piano  
for taps mounted on corner top



cm 70x37 h16,5 Pallet Italia pz.21 Pallet export pz.35 Europallet pz.30 kg.12

### Lavabo da appoggio STOCKHOLM 45.37

Lavabo 45. Senza foro troppopieno. Per rubinetteria a muro o su piano. Installazione da appoggio. **LA045.BI**  
Countertop basin 45cm, with no overflow hole. Suitable for wall mounted taps or on counter.

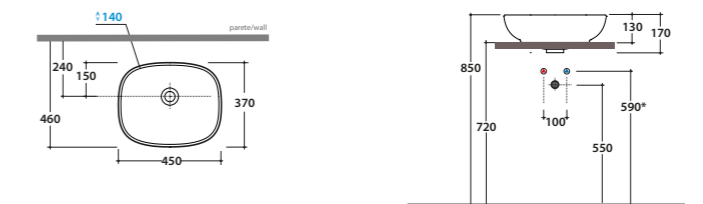

\* Per rubinetto su piano  
for taps mounted on corner top



cm 45x37 h16,5 Pallet Italia pz.36 Pallet export pz.60 Europallet pz.45 kg.9

### Piletta up and down

Piletta up and down per lavabi con troppo pieno  
Click-clack drain for basin provided with overflow



kg.0,5

### Sifone tondo

Sifone cromato a forma tonda 1" 1/4.  
Chromium-plated trap, round shape 1" 1/4.



RA051CR

kg.0,5

# Stockholm

## Lavabo STOCKHOLM 105.34

Lavabo 105 da incasso. Con foro troppo pieno  
Recessed basin 105cm. Provided with overflow hole

FO105.BI

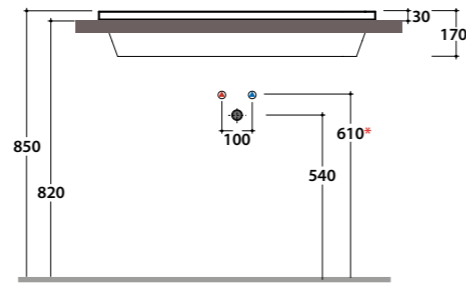
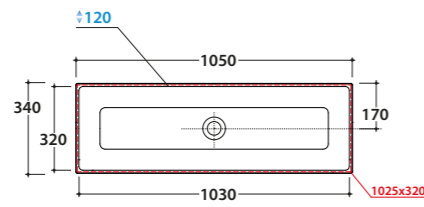

\* Per rubinetto su piano  
for taps mounted on corner top

cm 105x34 h17,5 Pallet Italia pz.15 Pallet export pz.25 Europallet pz.20 kg.22



## Lavabo STOCKHOLM 105.34

Lavabo sottopiano 105. Con foro troppo pieno. Fissaggi inclusi  
Under-top basin 105cm. Provided whit overflow. Fixing kit included

FO106.BI

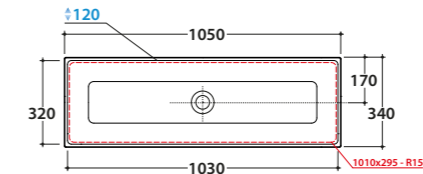

cm 105x34 h17,5 Pallet Italia pz.15 Pallet export pz.25 Europallet pz.20 kg.22



## Lavabo STOCKHOLM 90.34

Lavabo 90 da incasso. Con foro troppo pieno  
Recessed basin 90cm. Provided with overflow hole

FO090.BI

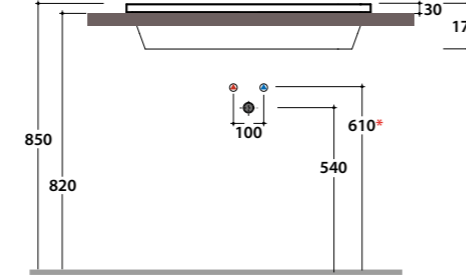
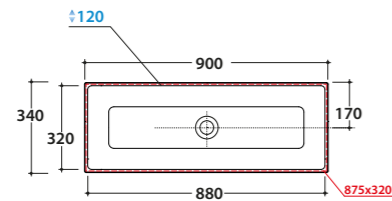

\* Per rubinetto su piano  
for taps mounted on corner top

cm 90x34 h17,5 Pallet Italia pz.18 Pallet export pz.30 Europallet pz.22 kg.19



## Lavabo STOCKHOLM 90.34

Lavabo sottopiano 90. Con foro troppo pieno  
Under-top basin 90. Provided whit overflow

FO091.BI

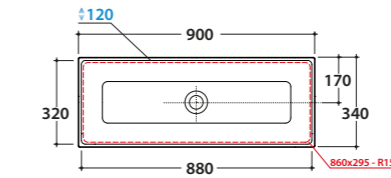

cm 90x34 h17,5 Pallet Italia pz.18 Pallet export pz.30 Europallet pz.22 kg.19



## Lavabo STOCKHOLM 75.34

Lavabo 75 da incasso. Con foro troppo pieno  
Recessed basin 75cm. Provided with overflow hole

FO075.BI

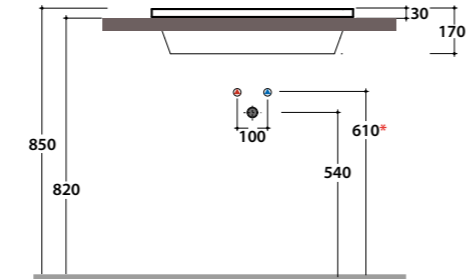
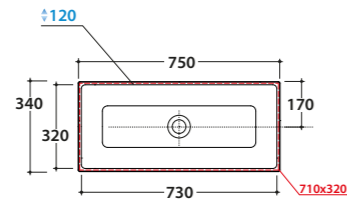

\* Per rubinetto su piano  
for taps mounted on corner top

cm 75x34 h17,5 Pallet Italia pz.21 Pallet export pz.35 Europallet pz.30 kg.17



## Lavabo STOCKHOLM 75.34

Lavabo sottopiano 75. Con foro troppo pieno  
Under-top basin 75. Provided whit overflow

FO076.BI

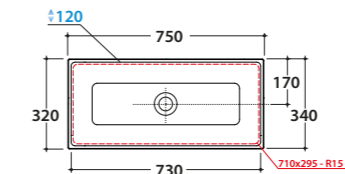

cm 75x34 h17,5 Pallet Italia pz.21 Pallet export pz.35 Europallet pz.30 kg.17



## Lavabo STOCKHOLM 55.34

Lavabo 55 da incasso. Con foro troppo pieno  
Recessed basin 55cm. Provided with overflow hole

FO056.BI

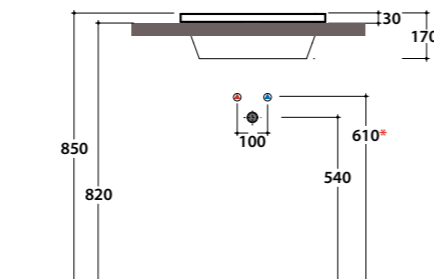
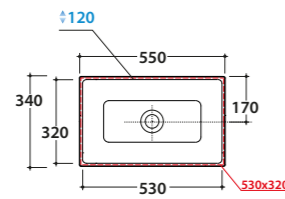

\* Per rubinetto su piano  
for taps mounted on corner top

cm 55x34 h17,5 Pallet Italia pz.30 Pallet export pz.50 Europallet pz.40 kg.12



## Lavabo STOCKHOLM 55.34

Lavabo sottopiano 55. Con foro troppo pieno  
Under-top basin 55. Provided whit overflow

FO057.BI

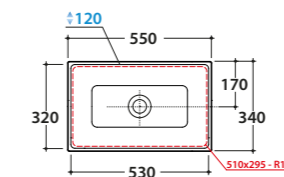

cm 55x34 h17,5 Pallet Italia pz.30 Pallet export pz.50 Europallet pz.40 kg.12



# Stockholm

## Vaso sospeso STOCKHOLM 58.37

Vaso sospeso con sistema di fissaggio dal basso nascosto. Scarico 4,5 / 3 Lt. Completo di fissaggi.  
Wall-hung WC provided with lower hidden fixing system. Drain 4,5 / 3 Lt. Fixing kit included.

LAS02.BI

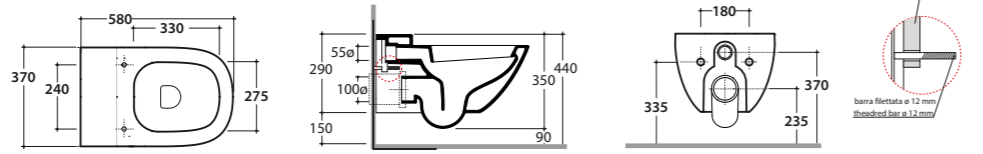

cm 58x37 h35 Pallet Italia pz.15 Pallet export pz.25 Europallet pz.20 kg.21

## Coprivaso chiusura tradizionale

Coprivaso rimovibile in termoindurente con cerniere cromate.  
Removable thermo-setting seat-cover with chromium-plated hinges.

LA019BI

## Coprivaso chiusura rallentata

Coprivaso rimovibile in termoindurente chiusura rallentata.  
Removable thermo-setting seat-cover with soft-closing system.

LA020BI

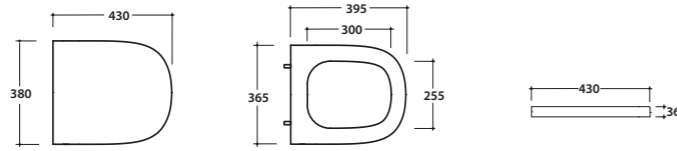

Pallet Italia pz.90 Pallet export pz.165 Europallet pz.115 kg.3,5

## Riduttore flusso di scarico

Riduttore flusso di scarico.  
Flow reductor.

VA132



## Bidet sospeso STOCKHOLM 58.37

Bidet sospeso monoforo con sistema di fissaggio dal basso nascosto. Completo di fissaggi.  
Wall-hung bidet provided with lower hidden fixing system. Fixing kit included.

LAS09.BI

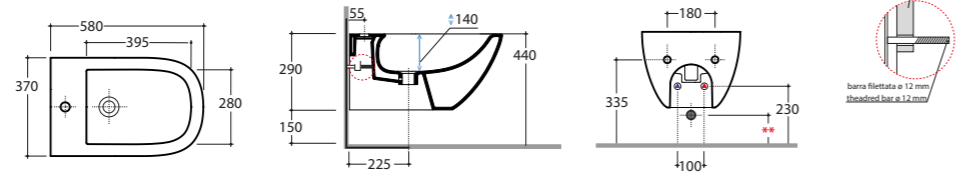

\*\* Per installazione con / For installation with  
- Sifone a "S" / Siphon "S" - mm 140  
- Sifone SF052 / Siphon SF052 - mm 120



cm 58x37 h30 Pallet Italia pz.15 Pallet export pz.25 Europallet pz.20 kg.20

## Staffa di fissaggio

Staffa di fissaggio a "L".  
Fixing brackets for W/H sanitary.

FI002



## Protezione

Protezione antiurto e acustica.  
Acoustic and crash protection.

kg.2,5

PU001

kg.0,2



## VASOGHOST® a terra STOCKHOLM 58.37

Vaso a terra con carico e scarico acqua regolabile MULTI. Scarico parete trasformabile a pavimento tramite curva tecnica fornita a richiesta. installazione filo parete. Scarico 4,5/3 Lt. Completo di FISSAGGIOGHOST®.  
Floor mounted WC with adjustable water inlet/outlet MULTI. Wall drain turning into floor drain by means of the PVC pipe supplied on demand. Back to wall installation. Drain 4,5/3 Lt. FISSAGGIOGHOST® fixing kit included.

LA001.BI

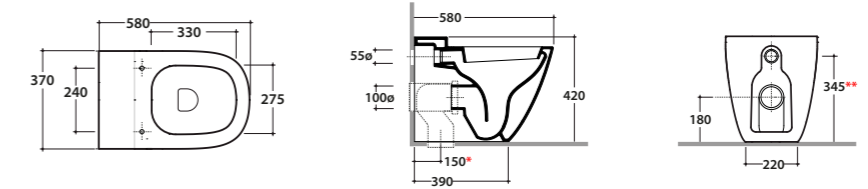

cm 58x37 h42 Pallet Italia pz.15 Pallet export pz.20 Europallet pz.16 kg.27

## Coprivaso chiusura tradizionale

Coprivaso rimovibile in termoindurente con cerniere cromate.  
Removable thermo-setting seat-cover with chromium-plated hinges.

LA019BI

## Coprivaso chiusura rallentata

Coprivaso rimovibile in termoindurente chiusura rallentata.  
Removable thermo-setting seat-cover with soft-closing system.

LA020BI

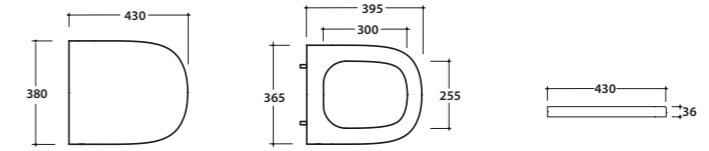

Pallet Italia pz.90 Pallet export pz.165 Europallet pz.115 kg.3,5

## Curva tecnica \*

Raccordo per scarico a pavimento regolabile da 6 a 12 cm.  
Elbow pipe for floor drain. Adjustable 6/12 cm.

VA077



Ø 10

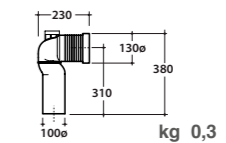

## Curva tecnica \*

Raccordo per scarico a pavimento regolabile da 17 a 21 cm.  
Elbow pipe for floor drain. Adjustable 17/21 cm.

VA078



Ø 10

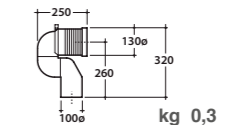

## Curva tecnica \*

Curva tecnica per lo scarico a pavimento regolabile da 13 a 16 cm.  
Elbow pipe for floor drain. Adjustable 13/16 cm.

VA079



Ø 11

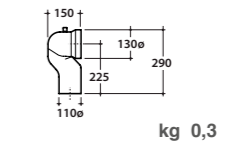

## Raccordo eccentrico \*\*

Raccordo eccentrico per carico acqua cm. 36 o 33.  
Pipe for drain 36/33 cm.

VA086



Ø 4

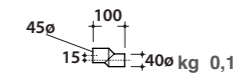

## Raccordo a parete

Raccordo per scarico a parete cm. 35.  
Pipe for wall drain 35cm.

VA076



Ø 11

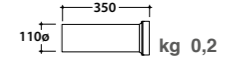

## Riduttore flusso di scarico

Riduttore flusso di scarico.  
Flow reductor.

VA132



## BIDETMULTI® a terra STOCKHOLM 58.37

Bidet a terra monoforo. Installazione filo parete. Completo di FISSAGGIOGHOST®.  
Floor mounted bidet one hole. Back to wall installation. FISSAGGIOGHOST® fixing kit included.

LA009.BI

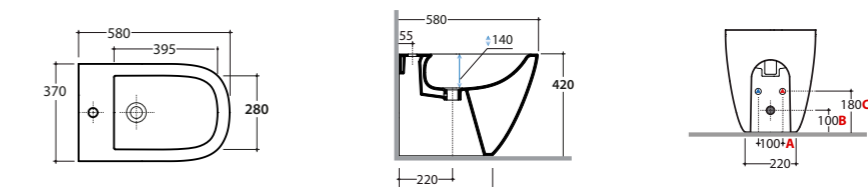

cm 58x37 h42 Pallet Italia pz.15 Pallet export pz.20 Europallet pz.16 kg.24

A da 50 a 160 B da 85 a 130 C da 170 a 220

**Vaso-Bidet terra  
STOCKHOLM 58.37**



Vaso-Bidet a terra con carico e scarico acqua regolabile MULTI. Scarico parete trasformabile a pavimento tramite curva tecnica fornita a richiesta. Installazione filo parete. Scarico 4,5 / 3 Lt. Completo di FISSAGGIOGHOST®.  
Floor mounted WC-bidet with adjustable water inlet/outlet MULTI. Wall drain turning into floor drain by means of the PVC pipe supplied on demand. Back to wall installation. Drain 4,5 / 3 Lt. FISSAGGIOGHOST® fixing kit included.

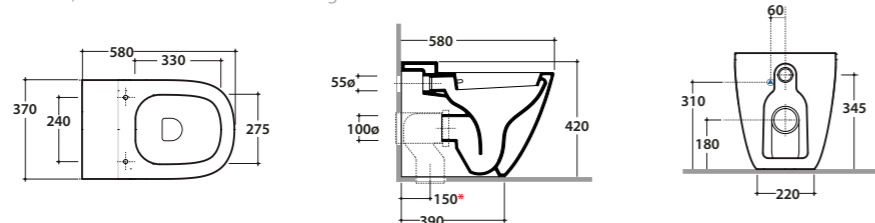

cm 58x37 h42 Pallet Italia pz.15 Pallet export pz.20 Europallet pz.16 kg.27



**Coprivaso chiusura tradizionale** Coprivaso rimovibile in termoindurente con cerniere cromate.  
Removable thermo-setting seat-cover with chromium-plated hinges.

LAB01.BI

LA019BI

**Coprivaso chiusura rallentata** Coprivaso rimovibile in termoindurente chiusura rallentata.  
Removable thermo-setting seat-cover with soft-closing system.

LA020BI

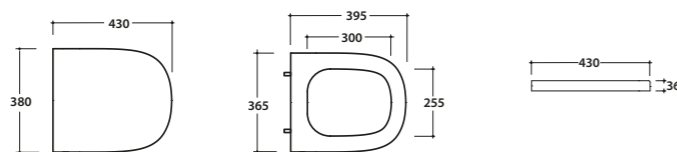

Pallet Italia pz.90 Pallet export pz.165 Europallet pz.115 kg.3,5

**Curva tecnica \***



Raccordo per scarico a pavimento regolabile da 6 a 12 cm.  
Elbow pipe for floor drain. Adjustable 6/12 cm.

Ø 10

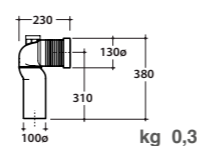

kg 0,3

VA077

**Curva tecnica \***



Raccordo per scarico a pavimento regolabile da 17 a 21 cm.  
Elbow pipe for floor drain. Adjustable 17/21 cm.

Ø 10

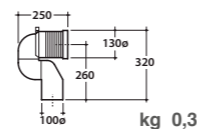

kg 0,3

VA078

**Curva tecnica \***



Curva tecnica per lo scarico a pavimento regolabile da 13 a 16 cm.  
Elbow pipe for floor drain. Adjustable 13/16 cm.

Ø 11

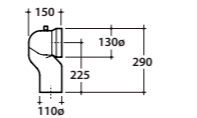

kg 0,3

VA079

**Raccordo a parete**



Raccordo per scarico a parete cm. 35  
Pipe for wall drain 35cm.

Ø 11

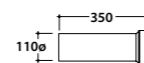

kg 0,2

VA076

**Riduttore flusso di scarico**



Riduttore flusso di scarico.  
Flow reductor.

VA132

**Vaso-Bidet sospeso  
STOCKHOLM 58.37**



Vaso-bidet sospeso con sistema di fissaggio dal basso nascosto. Scarico 4,5 / 3Lt  
Wall-hung WC-Bidet provided with lower hidden fixing system. Drain 4,5 / 3 Lt.

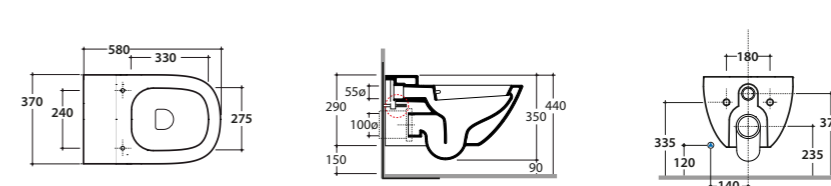

cm 58x37h35 Pallet Italia pz.15 Pallet export pz.25 Europallet pz.20 kg.21



**Coprivaso chiusura tradizionale** Coprivaso rimovibile in termoindurente con cerniere cromate.  
Removable thermo-setting seat-cover with chromium-plated hinges.

LAB02.BI

LA019BI

**Coprivaso chiusura rallentata** Coprivaso rimovibile in termoindurente chiusura rallentata.  
Removable thermo-setting seat-cover with soft-closing system.

LA020BI

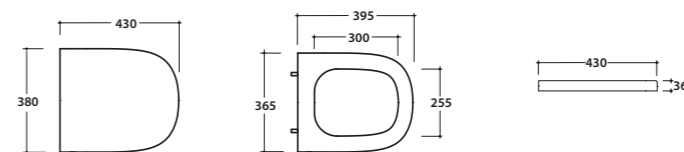

Pallet Italia pz.90 Pallet export pz.165 Europallet pz.115 kg.3,5

**Staffa di fissaggio**



Staffa di fissaggio a "L".  
Fixing brackets for W/H sanitary.

FI002

**Protezione**



Protezione antiurto e acustica.  
Acoustic and crash protection.

kg.2,5

PU001

kg.0,2

**RICAMBI PER COPRIVASI DA019BI E DA020BI / Spare parts for toilet seats DA019BI and DA020BI**

**Gommini paracolpi per coprivasi**  
Bumpers set for seat-cover  
Set di ricambio paracolpi per LA019BI e LA020BI  
Spare bumpers set for LA019BI and LA020BI

PAR66

**Coppie cerniere per coprivasi**  
Hinges set for seat-cover  
Set di ricambio coppie cerniere per LA019BI.  
Spare hinges set for LA019BI.

CRQ01

Set di ricambio coppie cerniere per LA020BI.  
Spare hinges set for LA020BI.

CRQ02

## Cassette di scarico GLOBO / Cistern flush GLOBO

### Cassetta di scarico per vasi sospesi



Cassetta di scarico ad incasso a tasto doppio per vasi sospesi. Scarico parziale 3lt, scarico totale 4,5lt.  
*Cistern flush built-in to double button for wall-hung pan. 3l partial discharge, total discharge 4,5lt.*

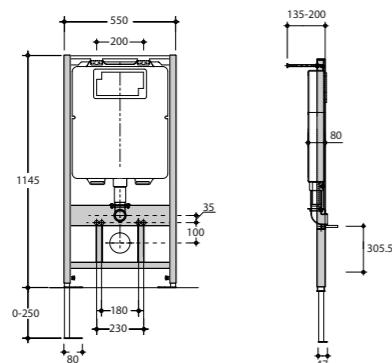

**CAINSO1**

**Kg.21**

### Cassetta di scarico per vasi terra



Cassetta di scarico ad incasso a tasto doppio per vasi da terra. Scarico parziale 3lt, scarico totale 4,5lt.  
*Cistern flush built-in to double key for floor mounted pan. 3l partial discharge, total discharge 4,5lt.*

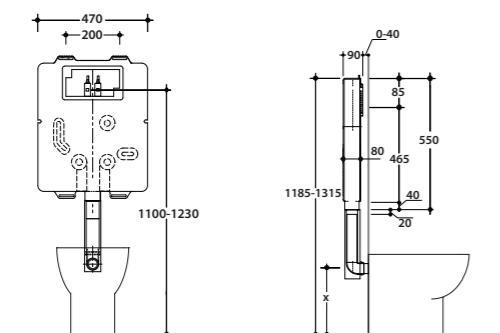

**CAINTE1**

**kg.6**

### Placca di comando

Placca di comando bianco lucido.  
*Control plate glossy white.*

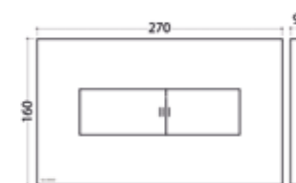

**PL01BI**

**kg. 0.6**

Placca di comando bianco opaco.  
*Control plate matt white.*



**PL01BO**

Placca di comando cromo.  
*Control plate chrome.*



**PL01CR**

Placca di comando nero opaco.  
*Control plate matt black.*



**PL01AR**

Placca di comando oro.  
*Control plate gold.*



**PL01OR**

## Legenda Icone Icon Legend

Ceramica Globo propone un nuovo concetto di rappresentazione delle informazioni sul prodotto. Un linguaggio simbolico mirato a rendere più veloce la lettura e l'acquisizione dei dettagli tecnici.

Ceramica Globo proposes a new concept of representing product information. A symbolic language which makes easier the reading and quicker the acquisition of the technical details.



Predisposto monoforo diaframmato  
*Arranged for one tap hole*



**VASOMULTI®**



Monoforo  
*One tap hole*



**BIDETMULTI®**



Predisposto per rubinetteria su piano d'appoggio  
*Suitable for taps mounted on counter top*



Scarico doppio flusso (4,5/3 Lt)  
*Dual flush discharge mechanism (4,5/3 Lt)*



Predisposto per rubinetteria a muro  
*Suitable for wallmounted taps*



Fissaggi inclusi  
*Fixing kit included*



Lavabo per installazione sospesa  
*Basin suitable for wall-hung installation*



Sanitari a terra completi di FISSAGGIOGHOST®  
*Floor-mounted sanitarries with FISSAGGIOGHOST®*



Lavabo per installazione incasso  
*Basin suitable for recessed installation*



Fissaggio nascosto ad azionamento dal basso  
*Lower hidden fixing system*



Lavabo per installazione sottopiano  
*Basin suitable for under-counter installation*



Vaso con integrazione funzione bidet  
*Wc with integrated bidet function*



Con chiusura scarico  
*With discharge closing*



Vaso installazione a filo, scarico parete/pavimento  
*Wc back to wall installation, floor/wall drain*



Con foro troppo pieno  
*With overflow hole*



Bidet installazione a filo  
*Bidet back to wall installation*



Senza chiusura scarico  
*Without discharge closing*



Prodotto smaltato con CERASLIDE®  
*Glazed product with CERASLIDE®*



Senza foro troppo pieno  
*Without overflow hole*



Copriwater con sistema di cerniere a sgancio rapido  
*Seat-cover with hinge system to quick release*



## Colori disponibili Available colours

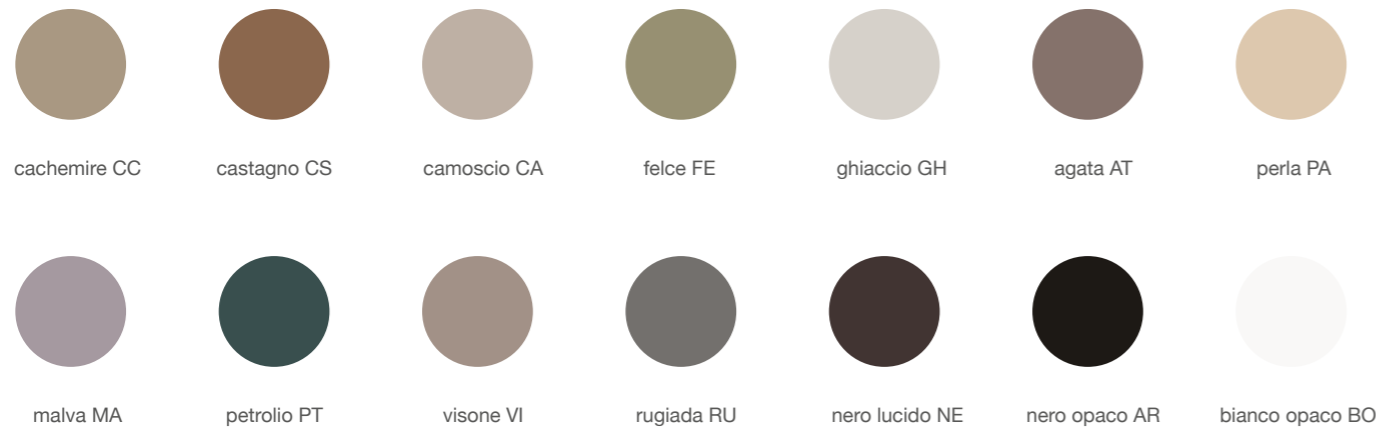

Le tonalità dei colori sono da ritenersi indicative in quanto possono variare in base alle modalità di stampa del catalogo.

*The colour tones are indicative, as they may change in relation to the printing method of the catalogue.*

### Composizione del codice Code composition

Per ordinare l'articolo relativo al prodotto colorato è necessario indicare il codice prodotto seguito dal codice della finitura scelta.

**Prodotto cod. LA102 + Finitura Agata AT = LA102.AT**

*To order the item relating to the coloured product, please indicate the product code followed by the code of the desired finish.*

**Product code LA102 + Agata AT Finish = LA102.AT**

### Listino Pricelist

Tutti i prodotti ceramici con finitura colorata hanno un incremento del 50% sul prezzo di listino del prodotto bianco ceramico

*The price for ceramic products with coloured finish is 50% higher than the price listed for the ceramic white product.*

### Qualità tecniche Technical quality

#### Ricerca

La ricerca e lo studio di nuove tonalità di colore ha portato la Ceramica Globo a sviluppare nuovi smalti ceramici colorati. Si contraddistinguono per le performance di stabilità di colore alle alte temperature di cottura, garantendo così delle rese cromatiche elevate.

#### Research

*The research and study of new colours has led Ceramica Globo to develop new coloured glazes for ceramics. They are characterised by the stability of the colours at high firing temperatures, thus ensuring high colour yield.*

#### Colore omogeneo

Il controllo della tonalità del colore viene effettuato costantemente da spettrofotometri elettronici, garantendo una qualità colorimetrica omogenea del prodotto finale.

#### Homogeneous colour

*The control of the colour tone is carried out constantly by electronic spectrophotometers, ensuring a homogeneous colourimetric quality of the final product.*

#### Superficie più igienica

Una particolare applicazione dello smalto permette di avere la superficie smaltata caratterizzata dalla estrema compattezza superficiale, garantendo pulizia e igiene.

#### More hygienic surfaces

*The special glazing technique allows obtaining an extremely compact glazed surface, thus ensuring cleanliness and hygiene.*

#### Pulizia

I test di laboratorio effettuati hanno dimostrato che i nostri smalti ceramici Matt hanno esattamente la stessa facilità di pulizia del normale bianco

#### Cleaning

*Laboratory tests have shown that these Matt ceramic glazes are just as easy to clean as normal white ceramic.*

## Claesson Koivisto Rune

**Claesson Koivisto Rune** nasce a Stoccolma nel 1995 da Mårten Claesson, Eero Koivisto e Ola Rune. Inizialmente fu concepito – e lo è tuttora – come studio di architettura, ma successivamente è diventato multidisciplinare, che in questo caso significa che il design del prodotto è praticato con la stessa enfasi.

**Claesson Koivisto Rune** was founded in Stockholm in 1995 by Mårten Claesson, Eero Koivisto and Ola Rune. It started as – and still is – an architectural office, but since has become multi-disciplinary, which in this case means that product design is also practiced with equal emphasis.



**Ceramica Globo spa**

Loc. La Chiusa . 01030 . Castel Sant'Elia - (VT) . Italy  
Tel.+39 0761 516568 . Fax+39 0761 515168

**Showroom** . Corso Monforte, 15 . 20122 Milano

Tel.+39 02 36521510 .  
Mail monforte15@ceramicaglobo.com

**Globo Concept Shop** . Shop C, Ground Floor

336-342 Lockhart Road . Wanchai, Hong Kong  
Tel. +(852) 2988 1904 . Fax +(852) 2988 1147

[info@ceramicaglobo.com](mailto:info@ceramicaglobo.com)

**follow us**



**ADIMEMBER**



Ceramics of Italy



[www.ceramicaglobo.com](http://www.ceramicaglobo.com)



**Concept and graphics**

Domenico Orefice Design Studio

**Photo**

Zerotremedia

**Styling e art buying:**

Ilaria Gerli

**Print**

Telligraf

2015 - all rights reserved ©

