

# MODE LAVABO ME080BI

CE EN 14688:2015

# GLOBO



Effetto antibatterico su ceramica BATAFORM®



Prodotto smaltato con CERASLIDE®



Bagno di Colore (Solo Bianco Opaco BO)

Cod. **ME080BI**

Lavabo 80.49 h20 cm. Installazione sospesa o su struttura.  
Completo di fissaggi. Peso 19,2 kg

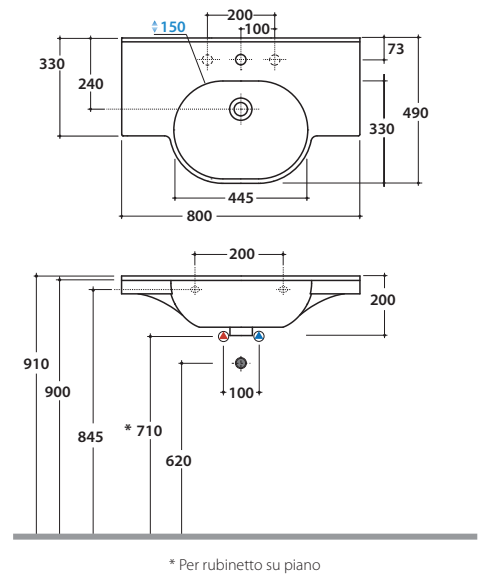

Cod. **FI012BI**

Piletta up and down con tappo in ceramica per lavabi con troppopieno. Peso 0,5 Kg



Cod. **FI012CR**

Piletta cromata up and down per lavabi con troppopieno. Peso 0,5 Kg

## MODE PORTASCIUGAMANI LATERALE ME001YAR PER LAVABI ME100 ME080

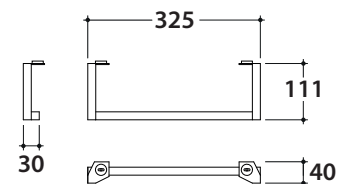
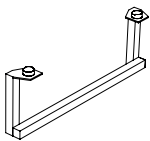

Finiture



Acciaio nero opaco

Cod. **ME001YAR**

Portasciugamani 32,5X4 h11 cm per lavabi ME100 e ME080. Peso 3 Kg.

## MODE STRUTTURA SOSPESA ME002SAR

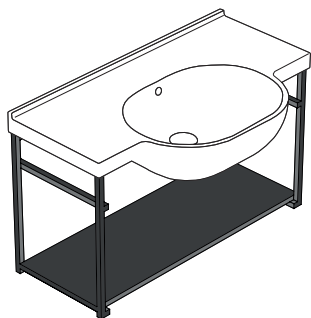

Finiture **S** Acciaio nero opaco

Cod. **ME002SAR**

Struttura sospesa in acciaio nero opaco 76,7x31,5 h42 cm. Per lavabo ME080. Peso 11 Kg

# GLOBO

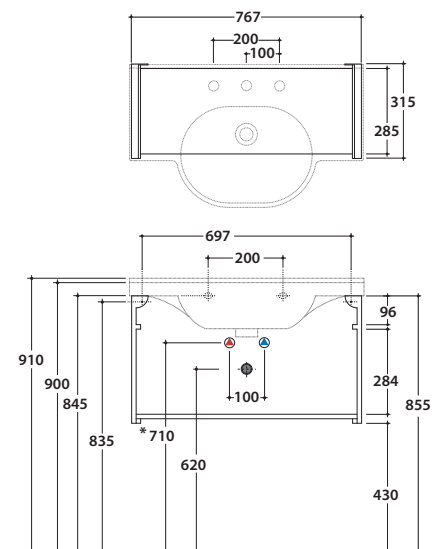

\* Per rubinetto su piano

## MODE STRUTTURA A TERRA ME004SAR

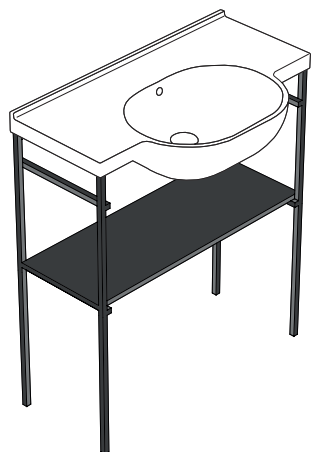

Finiture **S** Acciaio nero opaco

Cod. **ME004SAR**

Struttura a terra in acciaio nero opaco 76,7x31,5 h85,5 cm. Per lavabo ME080. Peso 10 Kg

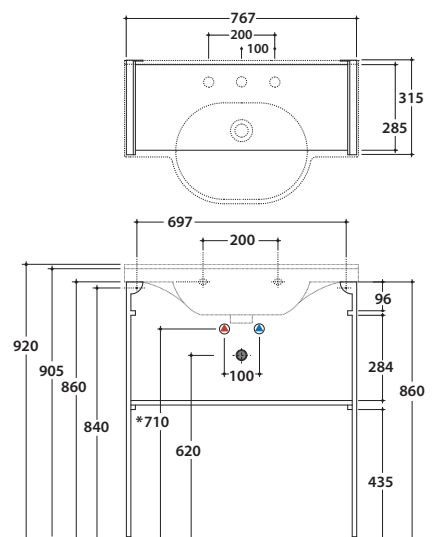

\* Per rubinetto su piano